

## ELECTRIC WINCH - HORIZONTAL DRIVE

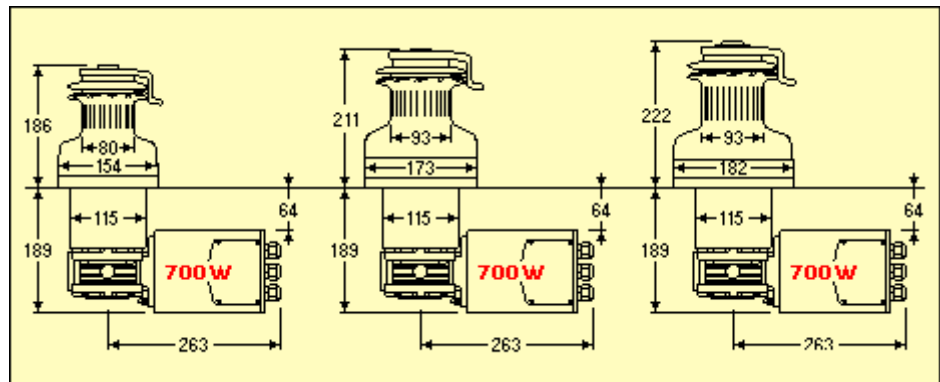

### HORIZONTAL DRIVE MOTOR 700 W 12/24 V

Three models 40, 44 and 48 ST are powered with a 700 watt motor. Two switches, one control box and one breaker complete the system. The 700 W motor is available in 12 and 24 volt versions. Please specify the voltage required (12 or 24) along with the electric model.



| MODEL                | W40ELH | W44ELH | W48ELH |
|----------------------|--------|--------|--------|
| LINE SPEED 1 (m/min) | 15.0   | 12.0   | 9.5    |
| LINE SPEED 2 (m/min) | 5.5    | 5.5    | 5.0    |
| WORKING LOAD (kg)    | 800    | 800    | 1000   |
| GLOBAL WEIGHT (kg)   | 17.9   | 20.6   | 22.4   |



**HORIZONTAL DRIVE  
MOTOR 1000 W 12/24 V**

Models 52 and 60 ST are powered with a 1000 Watt, 12 or 24 Volt motor. Two switches, one control box and one breaker complete the system.

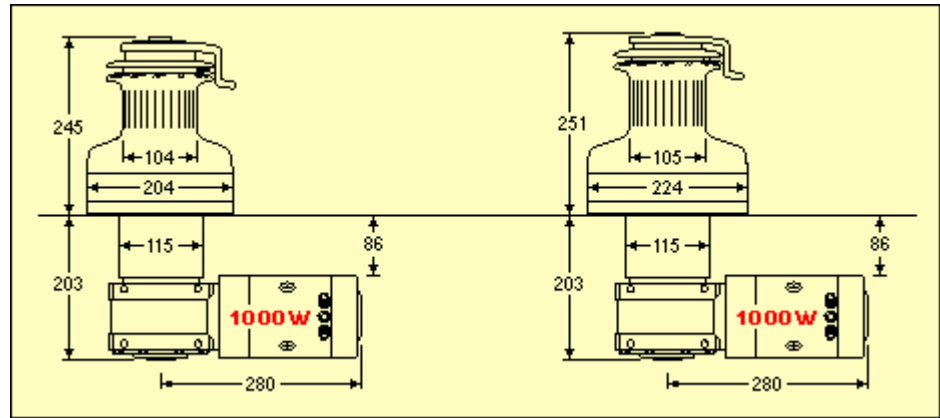

| MODEL                | W52ELH | W60ELH |
|----------------------|--------|--------|
| LINE SPEED 1 (m/min) | 16.0   | 12.7   |
| LINE SPEED 2 (m/min) | 4.6    | 3.9    |
| WORKING LOAD (kg)    | 1200   | 1400   |
| GLOBAL WEIGHT (kg)   | 29.3   | 31.1   |



## HORIZONTAL DRIVE MOTOR 1500 W 12/24 V

Models 65 and 70 ST are powered with a 1500 Watt, 12 or 24 Volt motor. Two switches, one control box and one breaker complete the system.

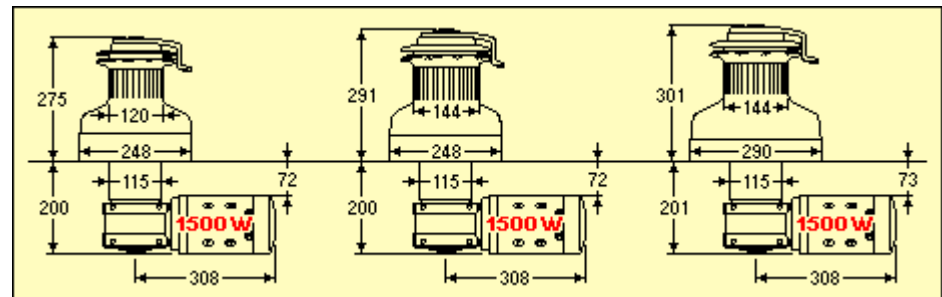

| MODEL                | W65ELH | W66ELH | W70ELH |
|----------------------|--------|--------|--------|
| LINE SPEED 1 (m/min) | 8.0    | 13.0   | 8.7    |
| LINE SPEED 2 (m/min) | 3.6    | 3.6    | 3.3    |
| WORKING LOAD (kg)    | 2300   | 2600   | 2900   |
| GLOBAL WEIGHT (kg)   | 40.1   | 43.0   | 48.6   |

**LINE SPEED:** the recovery speed is calculated with the winch not under load; at maximum load the figure should be reduced by 30%.

**MANUAL USE:** the gearbox-motor unit is disengaged simply by inserting the handle.

All our electric winches are self tailing and come supplied with a chrome-plated bronze drum.