

## SELF TAILING WINCHES

### ONE REDUCED SPEED

The two smallest models (W16 and W30) have a single reduced gear, giving a slow but powerful force. The handle turns freely the other way. Marine bronze base and gears, AISI 316 stainless steel central rod and bearings, black anodized aluminium (AL) or chrome-plated bronze (BR) drums.



### TWO SPEED: DIRECT AND REDUCED

The addition of a direct gear to the models described above gives a faster recovery speed, which, combined with reduced weight and bulk, makes the two speed models the best choice for racing.

W16.2 ST is available only in black aluminium version.

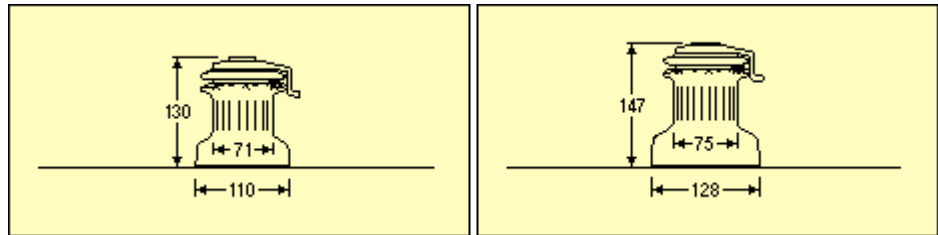

MODEL	W16ST	W16.2ST	W30ST	W30.2ST
POWER P1-P2	14.5	7.3 / 14.5	28.0	6.8 / 28.0
RECOVERY S1-S2 (mm)	110	220 / 110	60	235 / 60
Ø LINE (mm)	8 / 12	8 / 12	8 / 12	8 / 12
WEIGHT AL (kg)	2.60	3.10	3.30	4.50
WEIGHT BR (kg)	3.60	- - -	4.20	5.40
SCREWS N x Ø (mm)	5 x Ø6	5 x Ø6	5 x Ø6	5 x Ø6



## TWO REDUCED SPEED

All these models have 2 reduced speeds, spring loaded self-tailer which adapt automatically to the rope's diameter and pre-assembled bases produced by the C.N.C<sup>1</sup>. process in aluminium and bronze, which are lighter and stronger than normal castings. The central rod and roller bearings are made of AISI 316 stainless steel, with marine bronze gears and black anodized aluminium (AL) or chrome-plated bronze (BR) drums.

All these models are available with electric motors or hydraulic motors.

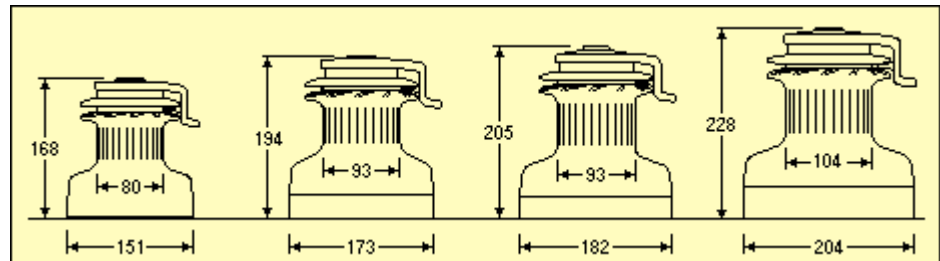

MODEL	W40ST	W44ST	W48ST	W52ST
POWER P1-P2	12.8 / 40.0	20.0 / 43.0	24.6 / 46.3	14.9 / 51.1
RECOVERY S1-S2 (mm)	125 / 40	80 / 38	65 / 35	107 / 31
Ø LINE (mm)	6 / 14	8 / 16	8 / 16	10 / 18
WEIGHT AL (kg)	4.60	6.70	7.80	9.10
WEIGHT BR (kg)	6.20	9.80	11.00	13.00
SCREWS N x Ø (mm)	5 x Ø8	6 x Ø8	6 x Ø8	6 x Ø8

## MODEL W66ST & W70ST

The new **W70ST** replaces the old version with two important innovations:

- All the gears are fitted with roller bearings;
- The drum works on a much larger roller and ball bearings.

The **W66ST** is a new model with a very large drum, same mechanics of the new W70ST, with all the gears on roller bearings and the drum on very large roller and ball bearings.

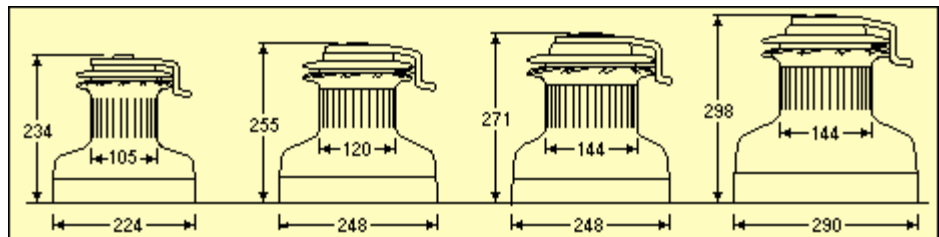
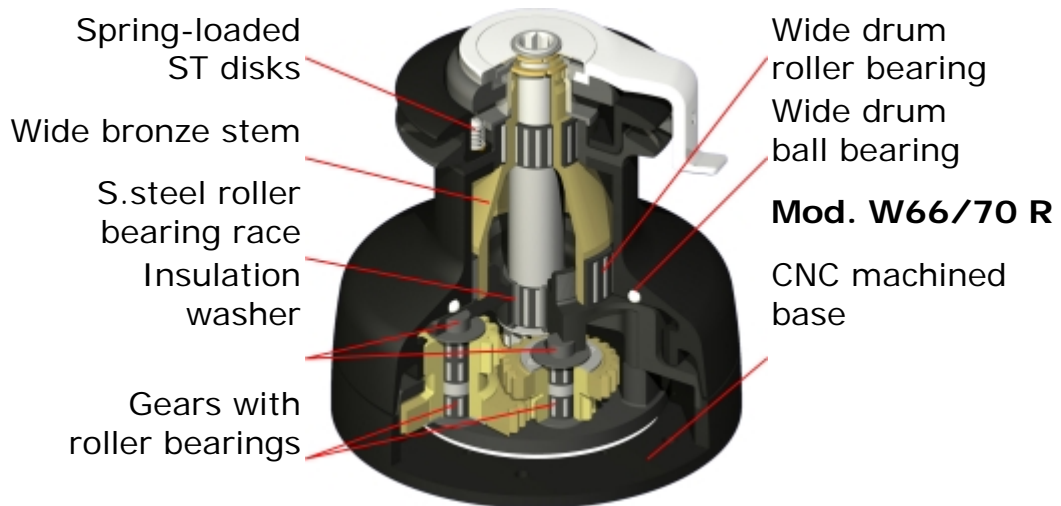

MODEL	W60ST	W65ST	W66ST	W70ST
POWER P1-P2	18.7 / <b>61.2</b>	26.2 / <b>65.2</b>	18.0 / <b>65.6</b>	27.1 / <b>69.8</b>
RECOVERY S1-S2 (mm)	85 / 26	61 / 24	89 / 24	59 / 23
Ø LINE (mm)	10 / 18	10 / 20	12 / 22	12 / 22
WEIGHT AL (kg)	11.00	14.50	16.50	21.40
WEIGHT BR (kg)	14.40	18.90	22.20	26.70
SCREWS N x Ø (mm)	6 x Ø10	6 x Ø10	6 x Ø10	6 x Ø10



Spring-loaded ST disks.



1 - Produced with computer numeric control machines with no cast components. All two reduced speed models come with this type of base.

<b>AL :</b>	with hard black anodized drum.
<b>BR :</b>	with chromed bronze drum.
<b>P1, P2 :</b>	power with the first (fast) and second (slow) gear.
<b>S1, S2 :</b>	recovery speed, the length of line recovered with one turn of the handle in first gear and in second gear.