

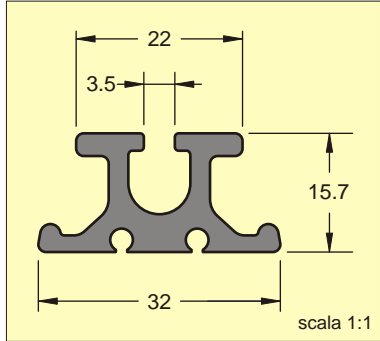

The following Antal system can be used on this new Antal track:

- ▶ HS 40 for boats up to 40 ft (Antal catalogue pg. 114);
- ▶ HS Race with # 60 batten car for boats up to 50 ft (pg. 116);
- ▶ HS Race with # 70 batten car for boats up to 60 ft (pg. 116).



## TRACK SIZES

**Mod. 601.120/C**

Aluminium profile hard black anodized and teflon coated.

Weight: 0.55 kg/m

Lengths of 3 m available.

## FIXING

The track will be glued to the mast (SP SYSTEM - SPABOND 345).

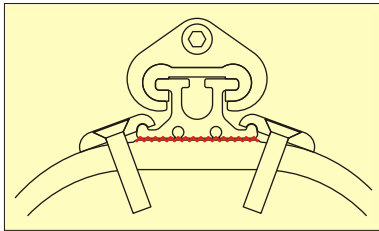

Fixing can be improved, on most loaded zones (mast head and reefing positions), with 2 alu side plates screwed to the mast.

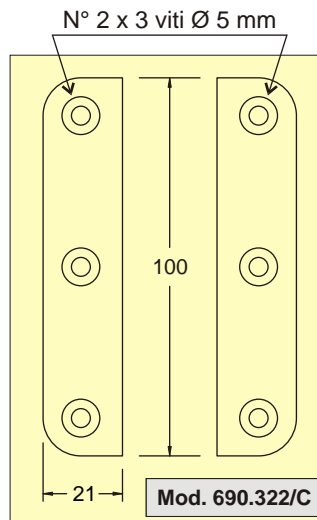

## ACCESSORIES

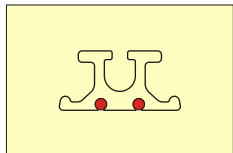

**Mod. 690.321/C**

### TRACK JOINT

Connection of different sections will be done with 2 s.steel pins.

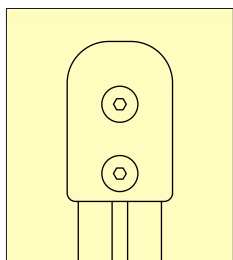

**Mod. 692.311/C**

### END-FITTING

for mast head.

**Mod. 602.321/C** **LOADER**

It allows the cars to be loaded and unloaded easily.  
L = 500 mm

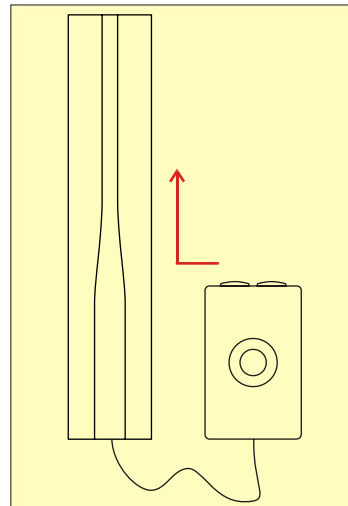

## BOLTROPE TRACK SIZE 90/130 FOR CARBON FIBER MAST

The following Antal system can be used on this new Antal track:

- HS 90 for boats up to 80 ft;
- HS 130 for boats up to 50 ft.

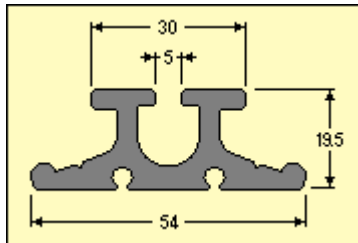

Mod. 601.122/C

### TRACK SIZES

Aluminium profile hard black anodized and teflon coated.

Weight: 1.1 kg/m

Lengths of 3 m available.

### FIXING

The track will be glued to the mast (SP SYSTEM - SPABOND 345)

For an easier gluing each track is fixed with 3 positioning screws.

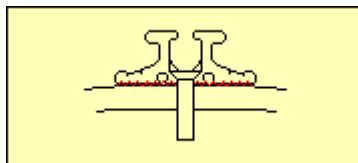

Fixing can be improved, on most loaded zones (mast head and reefing positions), with 2 alu side plates screwed to the mast.

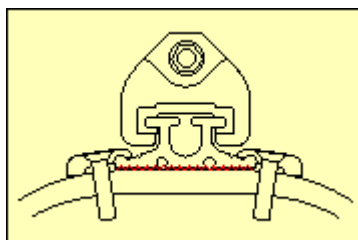

N° 2 x 4 screws Ø6 mm

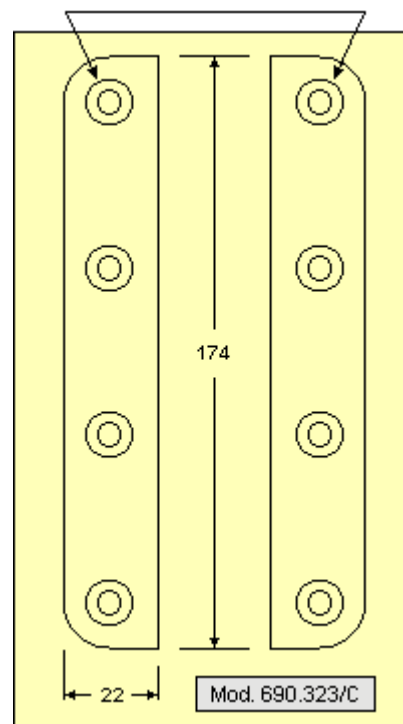

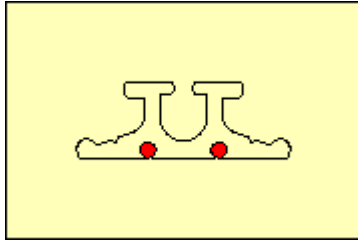

Mod. 690.325/C

### TRACK JOINT

Connection of different sections will be done with 2 s.steel pins.

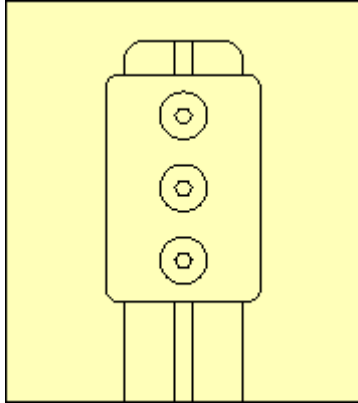

Mod. 692.811/C

### END-FITTING

for mast head.  
Fixing: n° 3 screws Ø6 mm.

Mod. 602.821/C

### LOADER

It allows the cars to be easily loaded and unloaded.

